



QuikBeam is a compact spotlight, delivers the power of a 200W Tungsten equivalent, with a 13°–60° Fresnel based zoom, swappable QuikBrick batteries, and built-in PoE.



App



Wireless DMX



Max 20h



IP65

SPECIFICATIONS

| Order Code | AST-QUKBM (without battery) | AST-QUKBM-STD (with battery) |
|---|--------------------------------|---------------------------------|
| LED Engine | Titan LED Engine | |
| Colors | RGBMintAmber | |
| Output Gain | Yes | |
| LED Power Draw | 20 W | |
| Tungsten Equivalent | 200 W | |
| Luminous Flux 2700 K | 1124 Lumens | |
| Luminous Flux 3200 K | 1190 Lumens | |
| Luminous Flux 4000 K | 1239 Lumens | |
| Luminous Flux 5500 K | 1285 Lumens | |
| Luminous Flux 6500 K | 1224 Lumens | |
| Candela 2700 K | 18545 cd | |
| Candela 3200 K | 19575 cd | |
| Candela 4000 K | 20312 cd | |
| Candela 5500 K | 20663 cd | |
| Candela 6500 K | 20564 cd | |
| Light Output 2700 K @ 3 m (13°) | 2059 Lux | |
| Light Output 3200 K @ 3 m (13°) | 2174 Lux | |
| Light Output 4000 K @ 3 m (13°) | 2257 Lux | |
| Light Output 5500 K @ 3 m (13°) | 2294 Lux | |
| Light Output 6500 K @ 3 m (13°) | 2285 Lux | |
| CRI (Ra) / TLCI 3200 - 6500 K* (OutputGain disabled) | ≥96 | |
| Beam Angle | 13° – 60° | |
| Field Angle | 16.9° – 78.2° | |
| Strobe | 0 - 25 Hertz | |
| Battery Runtime | – | up to 20 hours |
| Battery Runtime (max. Brightness) | – | 1 h 20 m |
| Charging Time (nominal) | – | 2 h 40 m |
| DC Input | PoE++ | |
| DC Connector | RJ45 | |
| Ethernet Port Speed | 100 Mbit/s | |
| Power Consumption (max.) | 40 W | |

| | | |
|----------------------------------|---|-------------------|
| ArtNet/sACN | via Ethernet | |
| CRMX Receiver | Built-in | |
| BluetoothBridge BTB | Built-in | |
| Wireless Protocols | CRMX, UHF, Bluetooth, WiFi | |
| Wireless Range | CRMX / UHF up to 300 m / 330 yds Bluetooth up to 3 m / 3.3 yds | |
| RDM Support | via CRMX | |
| Infrared Control | Yes | |
| IP Rating wired / unwired | IP65 | |
| Ambient Operating Temperature | 0 - 40 °C / 32 - 104 °F | |
| Weight | 1438 G / 3.17 LBS | 1617 g / 3.56 lbs |
| Dimensions (H x Ø) without yoke | 136 mm x Ø 120 mm / 5.35" x Ø 4.75" | |
| Dimensions (L x W x D) with yoke | 241 mm x 174 mm x 125 mm / 9.48" x 6.84" x 4.93" | |
| Mounting Options | 1/4" - 20 UNC, 3/8" - 16 UNC thread, Yoke (with AirlineTrack, 3/8" - 16 UNC thread, 1/2" hole) | |

All specifications provided are typical values and maybe subject to change without prior notice.

*OutputGain is designed for event use; for the best color rendering, it must be deactivated. Astera doesn't provide colour rendering values for this feature since it was never intended to replace the high quality whites of Titan LED Engine. Maximum battery runtime is the same with and without OutputGain

RF CHARACTERISTICS

| Wireless Modules | EU: UHF*** (863-870MHz) | USA: UHF (917-922.20MHz) | AUS: UHF (922.30-927.50MHz) | SGP: UHF (920.50-924.50MHz) | KOR: UHF (917.9-921.5MHz) |
|-------------------|----------------------------|-----------------------------|--------------------------------|--------------------------------|------------------------------|
| Modulation | FHSS | FHSS | FHSS | FHSS | FHSS |
| ERP (Transmitter) | <25mW | <25mW | <25mW | <25mW | <25mW |
| Channel Count | 47 | 53 | 53 | 41 | 10 |

| Wireless Modules | RUS: UHF (868.75-869.12MHz) | JPN: UHF (922.80-926.40MHz) | CRMX (2402-2480MHz) | Bluetooth 5.0 LE (2402-2480MHz) | WiFi (2412-2472MHz) |
|-------------------|--------------------------------|--------------------------------|------------------------|------------------------------------|------------------------|
| Modulation | FHSS | FHSS | FHSS | FHSS | DSSS, OFDM |
| ERP (Transmitter) | <25mW | <25mW | <100mW | 10mW (BLE) | <100mW |
| Channel Count | 6 | 19 | 79 | 40 | 13 |

***General allocation of frequencies for use by short-range radio applications

DRAWINGS

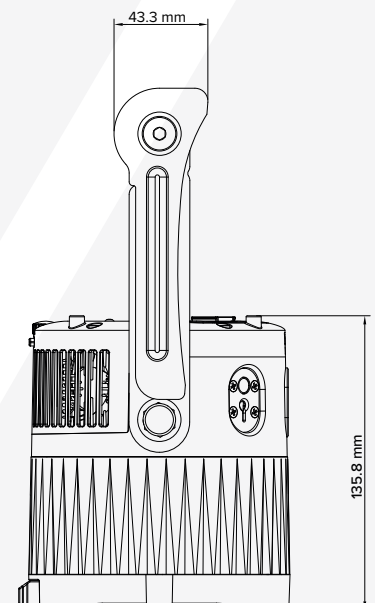
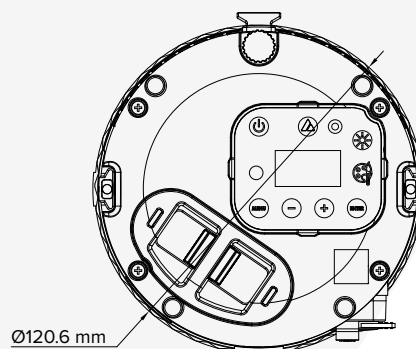
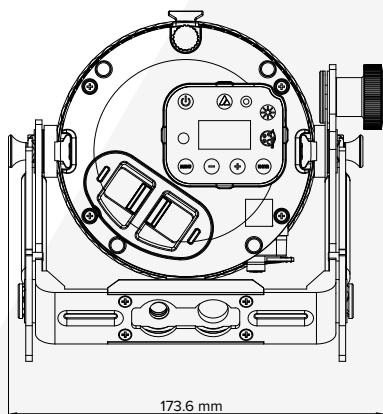

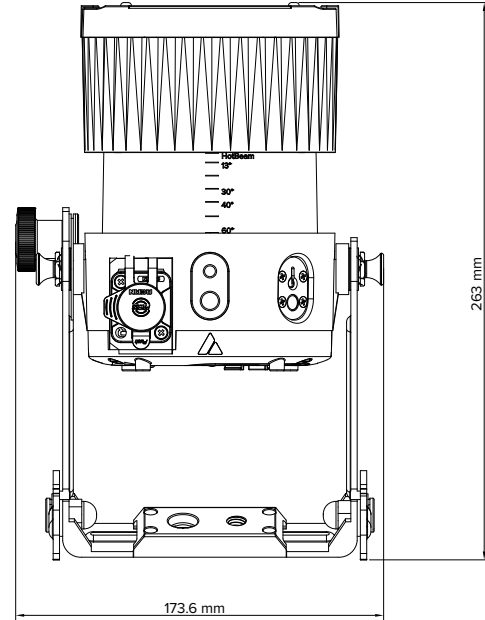
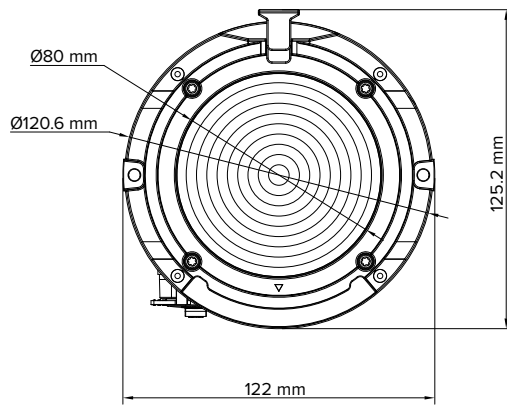
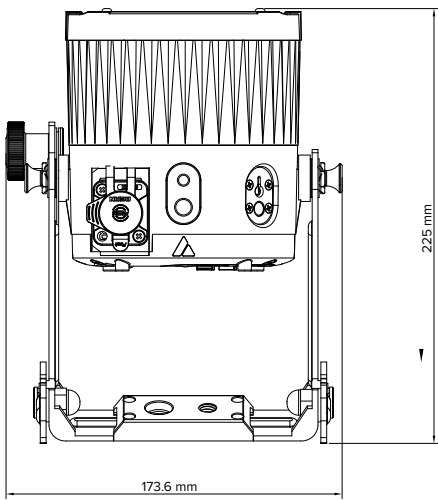

QUIK TURN

Rotate barrel counter-clockwise to zoom in. Zoom range: 13° to 60°

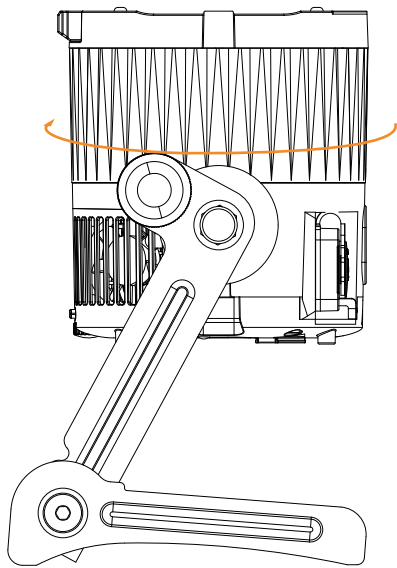

60° Zoom out

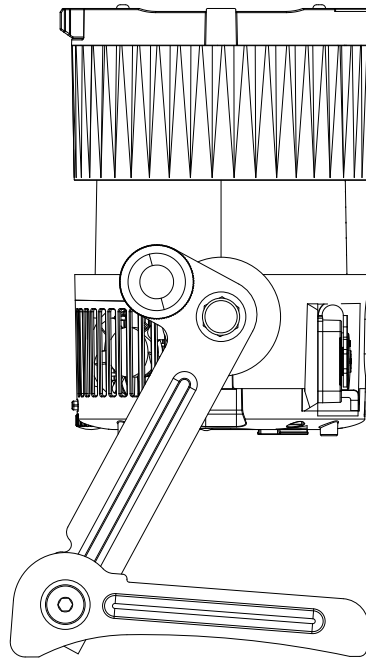

13° Zoom in

BACKSIDE

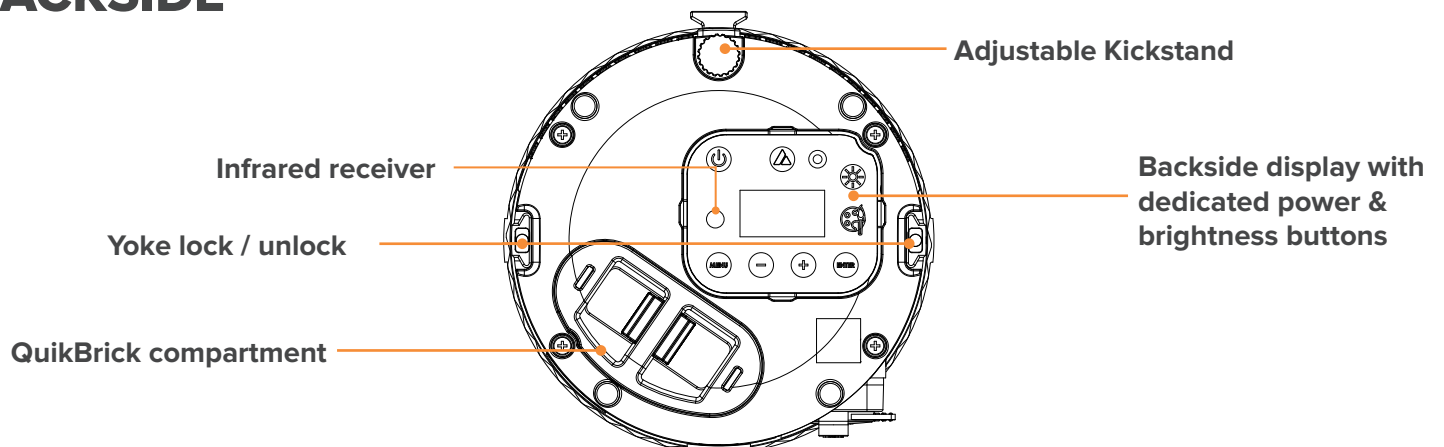

ACCESSORIES

QuikBrick

AST-QUKBM-QBK



NetBox

AST-NETBX



PowerInjector

AST-PWRIN



ChargingDock for 4 QuikBricks

AST-QUKBM-CHRDK-QBK



Barndoor

AST-QUKBM-BD



TrackSpigot 28/16

AST-TSP



TrackPin

AST-TP



TrackPin Compact

AST-TPC



FlexCover

AST-QUKBM-FLXCVR-MIR-8
AST-QUKBM-FLXCVR-WT-8

White

Mirror



EdgeSoftener Filter

AST-QUKBM-ES



Rotatable Filter 17°x46°

AST-QUKBM-RE



EyeBolt 1/4"

AST-EBLT-1/4



Yoke

AST-QUKBM-YK



Foldable

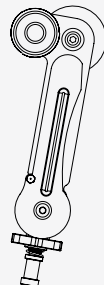
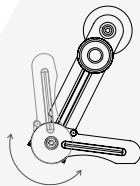

Yoke with
TrackPin Compact

Removeable

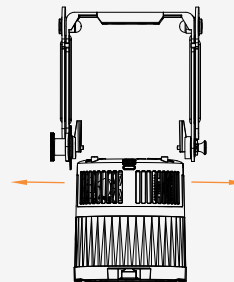

TYPICAL SPECTRAS

